

618 ACCU-SHARP SPIN/RELIEF REEL GRINDER

STANDARD FEATURES ::

ROBUST FRAME DESIGN - WELDED-STEEL FRAME AND POWDER COATED FINISH

TRAVERSE SYSTEM - AUTOMATIC BELT DRIVE VARIABLE SPEED USING PROXIMITY SENSORS COGGED TRAVERSE BELT WITH 38" TRAVEL CAPACITY

RAILS - PRECISION GROUND ROUND RAILS WITH RECIRCULATION BALL BEARINGS

VARIABLE SPEED SPIN DRIVE

VARIABLE TORQUE FOR RELIEF GRINDING

AUTO-INDEX RELIEF CAPABILITY

MANUAL HOIST

OPTIONAL EQUIPMENT ::

BEDKNIFE ATTACHMENT KIT - PART #6000555

BECAUSE FOLEY IS CONTINUALLY IMPROVING ITS PRODUCTS, SPECIFICATIONS ARE SUBJECT TO CHANGE WITHOUT NOTICE.

FOLEY
COMPANY

PRECISION AT PLAY

P: 1.715.426.5151

TOLL FREE: 1.800.225.9810

FOLEYCO.COM

WEIGHT :: 790 LBS (358 KG)

DIMENSIONS ::

TOP VIEW

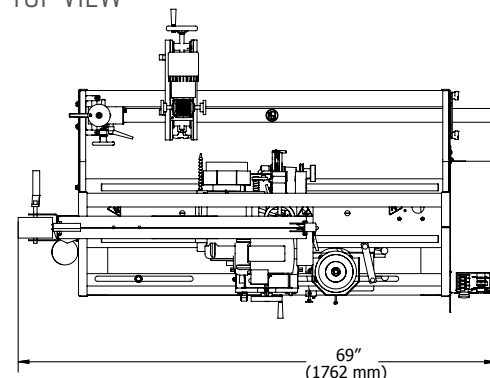

SIDE VIEW

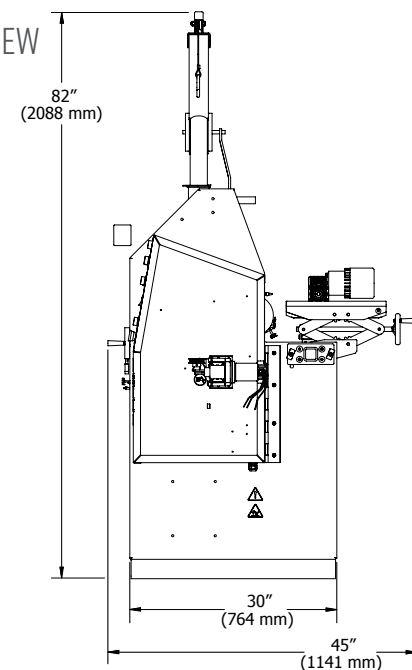

DISTRIBUTED BY:



MADE IN THE USA

©2019 FOLEY COMPANY. LIT-2019-10003

FOLEY
COMPANY



618 ACCU-SHARP
SPIN/RELIEF REEL GRINDER

ECONOMICAL FULL FEATURED REEL GRINDER

618 ACCU-SHARP SPIN/RELIEF REEL GRINDER



GAUGE, TOUCH-UP SPIN + RELIEF GRIND
WITH THE PATENTED AUTO-INDEX RELIEF SYSTEM FOR LESS

1 ADJUSTABLE REEL MOUNTING MECHANISM



2 BELT DRIVE TRAVERSE SYSTEM



3 SINGLE POINT INFEEED + CARRIAGE DESIGN



4 PATENTED AUTO-INDEX RELIEF ASSEMBLY



5 DUAL INDICATOR SET-UP GUAGE



6 ELECTRONIC TRAVEL LIMITS



7 ACCESSIBLE CONTROL PANEL



8 VARIABLE SPEED SPIN DRIVE

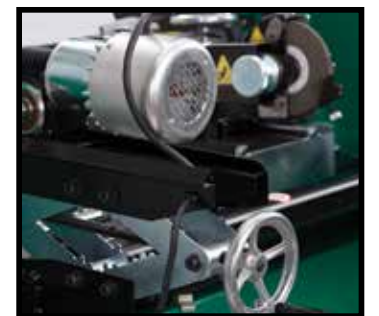

**A FULL FEATURED
ECONOMICAL
GRINDER**

LEARN MORE: FOLEYCO.COM



MANUAL HOIST

618 ACCU-SHARP OFFERS ::

PATENTED AUTO-INDEX RELIEF

LOWER LABOR COSTS, WHILE RETURNING REELS TO OEM SPECIFICATIONS.

ONE-PIECE WELDED FRAME CONSTRUCTION

MINIMIZES SPACE NEEDED TO NAVIGATE SET-UP AND OPERATION.